

2011/12/12 (14:08:33)

This drawing is provisional and subject to our reconfirmation and/or revision without notice.

DH1~DH2=32195 (±20)

Hole for stem removal

Coordinates

記号	X	Y	R
GM	0	0	—
DH1	-15200	-5300	—
DH2	15200	5300	—
b 1	3092	16654	320
b 2	-16920	800	320
b 3	-16920	-800	320
b 4	-800	-16920	320
b 5	800	-16920	320
b 6	16920	-800	320
b 7	16920	800	320

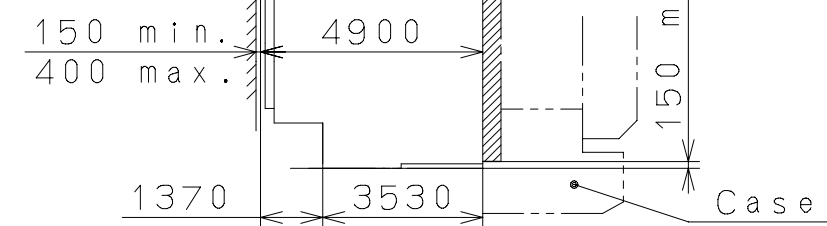
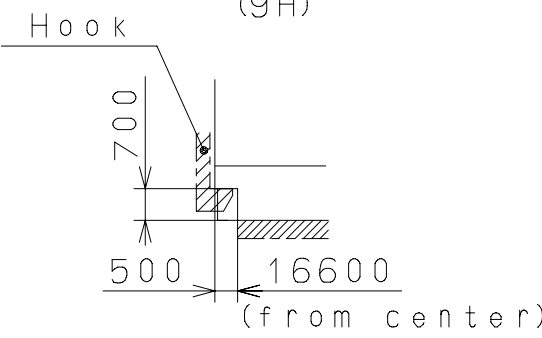
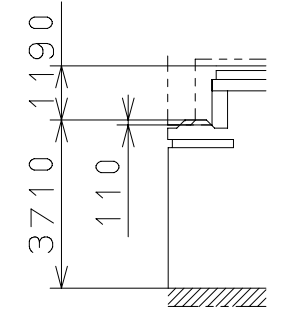
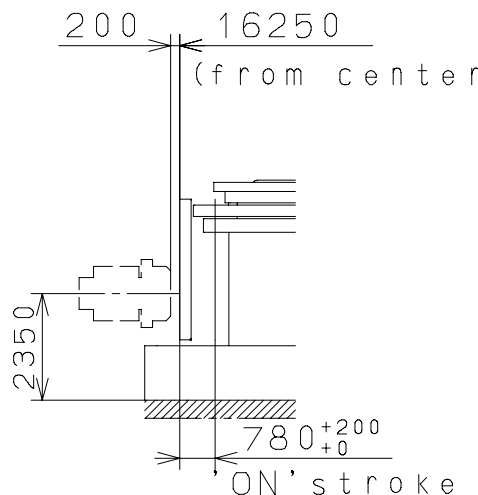
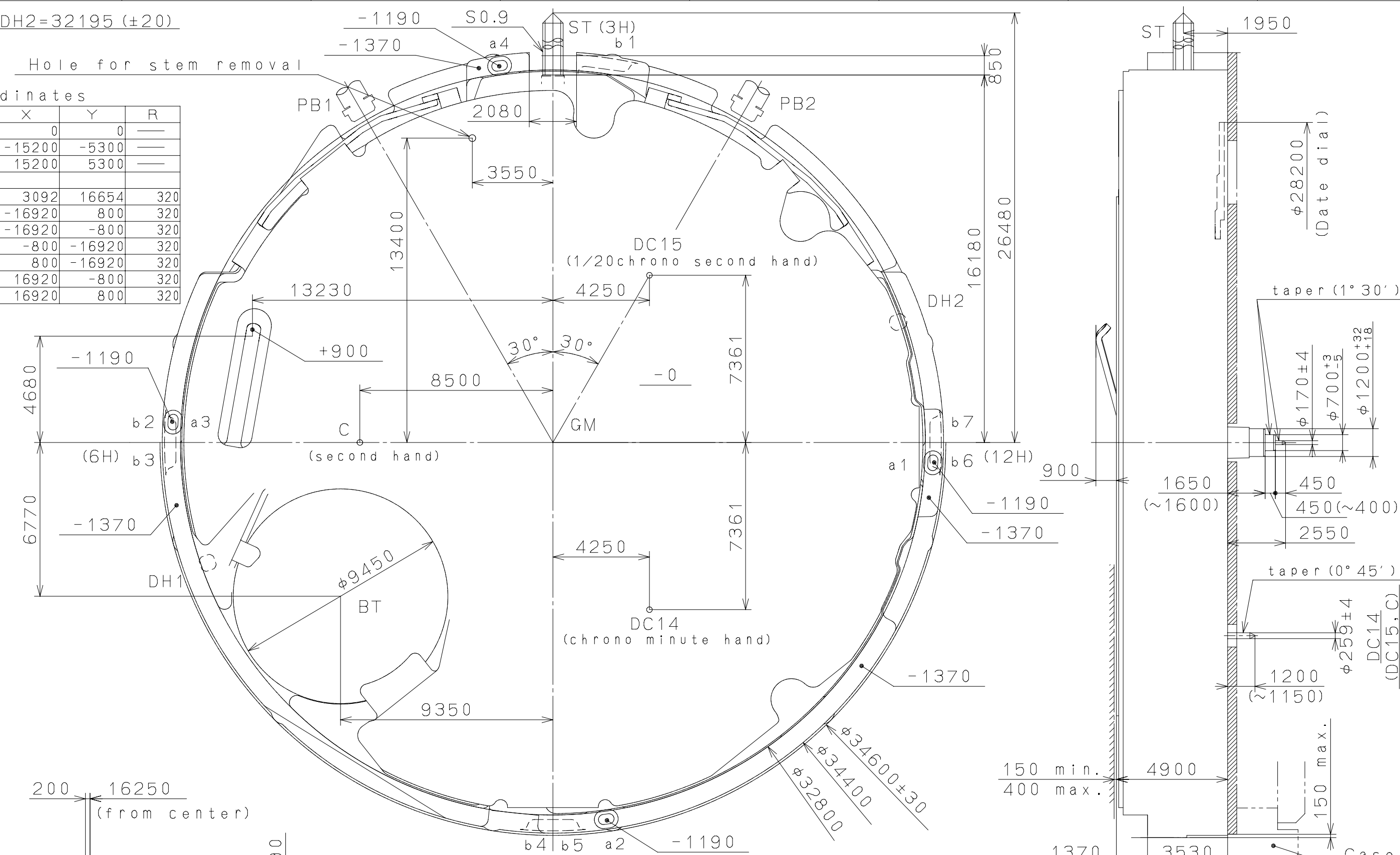

Quantity	Cal.NO.:	
Unit	1/1000mm	6S30
Scale	6 : 1	Parts No.:
Date		
Drawn		
Mark	Date	Description
		Alterations
Material	Checked	N. Suzuki
Heat Treatment	Approved	
Hardness		Name:
Plating		Frame for Case
	General Tolerances	Drawing No.: 6S30C001
	Dimensions	
	Angles	

MIYOTA

CITIZEN WATCH CO., LTD. TOKYO, JAPAN

2010/07/26 (09:02:03)

This drawing is provisional and subject to our reconfirmation and/or revision without notice.

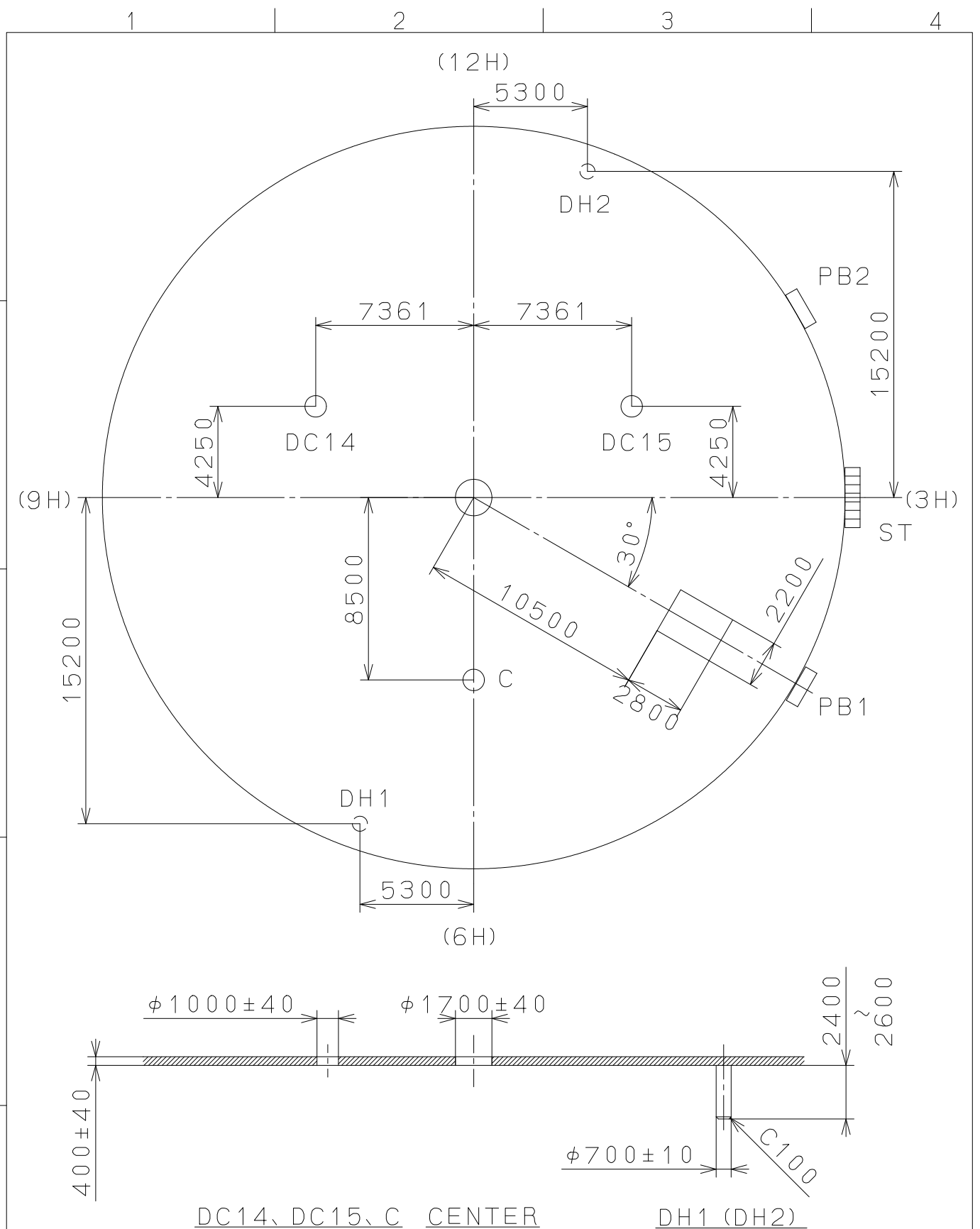

DC14、DC15、C CENTER

DH1 (DH2)

△			Quantity		Cal.NO.:
△			Unit	1/1000mm	6S30-00A
△			Scale	4:1	Parts No.:
△			Date		
△			Drawn		
Mark	Date	Description	Appr.	Checked	Name:
		Alterations	Approved	N. Suzuki	Indications for Dial
Material					Drawing No.: 6S30D000
Heat Treatment			General Tolerances		MIYOTA
Hardness			Dimensions		
Plating			Angles		
					CITIZEN WATCH CO., LTD. TOKYO, JAPAN

2010/07/26 (09:03:08)

This drawing is provisional and subject to our reconfirmation and/or revision without notice.

A
B
C
D
E
F

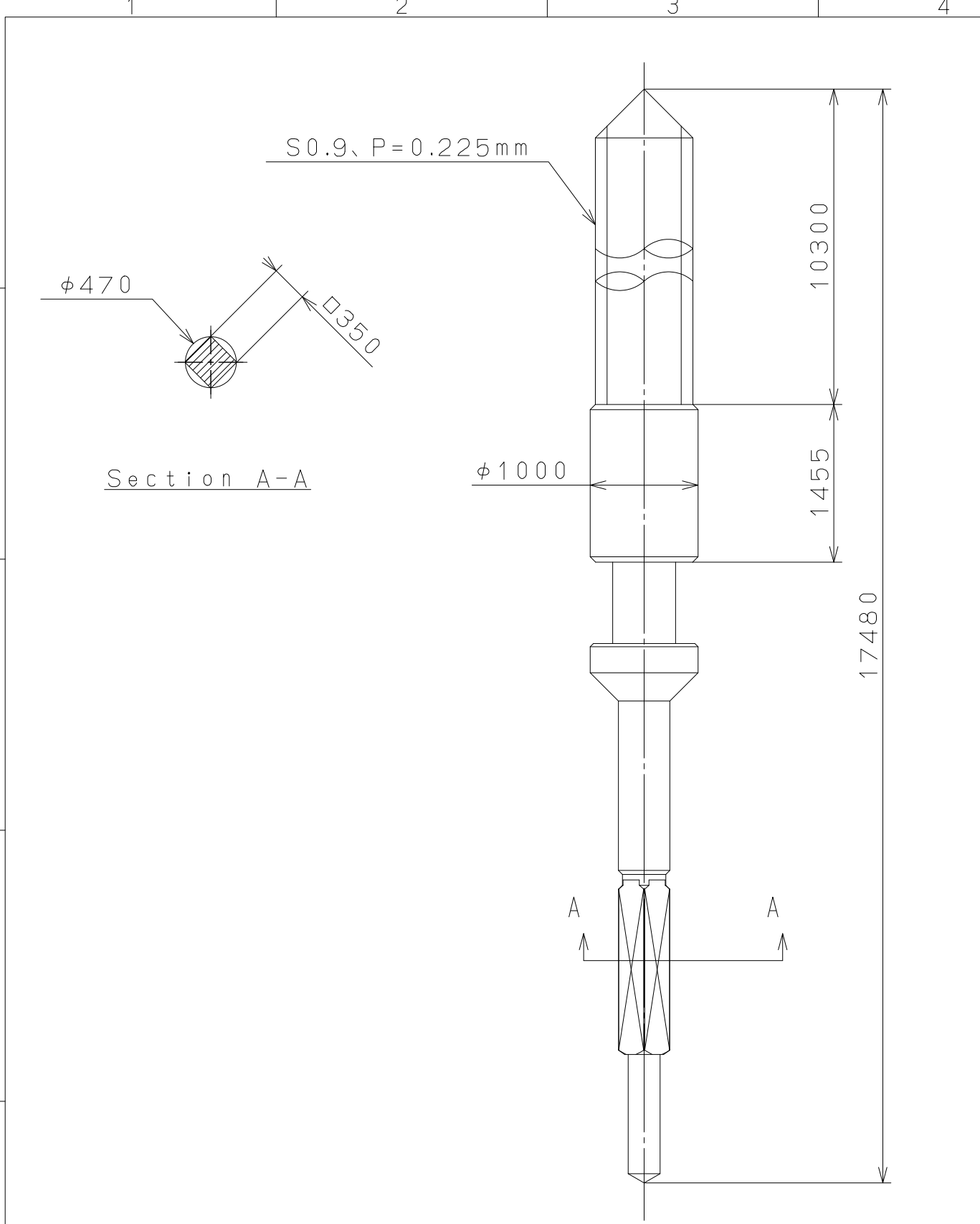

△5			Quantity		Cal.NO.:
△4			Unit	1/1000mm	
△3			Scale	20:1	Parts No.:
△2			Date		065-A13
△1			Drawn		
Mark	Date	Description	Appr.	Checked	Name:
		Alterations	Approved	N. Suzuki	SETTING STEM
Material					Drawing No.: A130S000
Heat Treatment			General Tolerances	MIYOTA CITIZEN WATCH CO., LTD. TOKYO, JAPAN	
Hardness			Dimensions		
Plating			Angles		