

Multipurpose Desktop Engraving Machine

Powerful performance in compact size

MAGIC™-E7





Multipurpose Desktop Engraving Machine, MAGIC™-E7

MAGIC-E7 is a 3rd generational desktop engraving machine with revolutionary functionality, structural stability, performance and design based on the CNC engraver application knowhow accumulated during the 1st through 2nd generations.

MAGIC-E7 boasts of user-friendly design, stronger performance, innovative usability and functionality, along with various device options expanding functionality that meets diverse customer needs. This customer-friendly multipurpose desktop engraver has aesthetic and modern design which looks wonderful in any places.

Key Point

- Multifunctional from jewelry manufacturing/engraving to industrial marking
- Easy to use and compact-sized for anyone to use
- Stronger cutting performance and 2 times higher resolution than that of the equivalent models
- Both flat clamp and rotary clamp embedded
- Supporting all- engraving, cutting, and marking
- Auto measuring of materials and tools
- Simple position control using a camera and laser guide
- Diverse clamps and auxiliary devices expanding functionality
- MagicArt7 software provided, easy and convenient to use

Purpose of use

- Jewelry manufacturing / marking
- Metal cutting / marking
- Identification marking
- 2.5D engraving
- Wood engraving
- Glass product marking
- Pen marking
- Name tag, label engraving
- Rubber stamp engraving
- Industrial marking

Main customers

- Jewelry workrooms / shops
- Jewelry workrooms / shops
- Customers who want to engrave or mark on various materials
- Customers who want to process materials for various purposes
- Handcraft workshops
- Souvenir shops



Product features

Stronger cutting performance

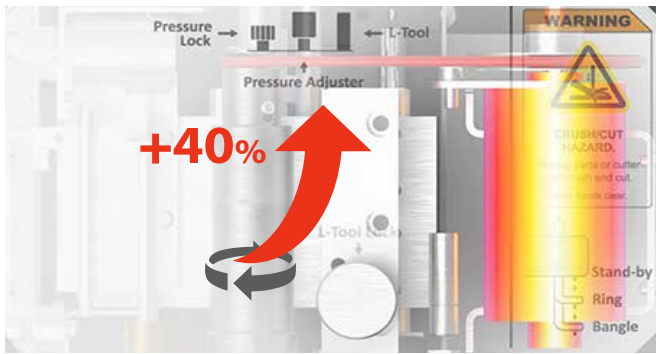

- Compared with other equivalent-level products, the motor cuts materials with about 40% stronger force.
- Faster cutting performance, improved cross section quality, and longer tool service life.

2 times higher resolution than the equivalent

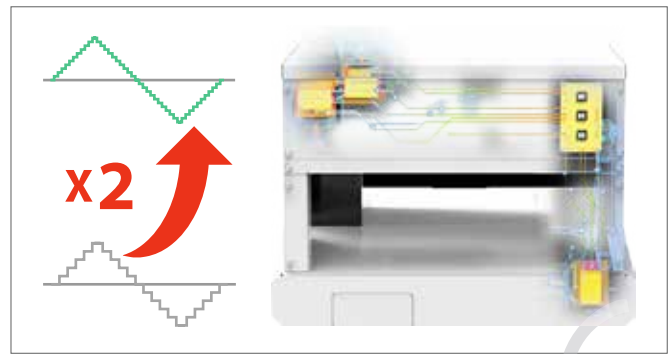

- The newly-developed 3rd generational motor control system controls the machine with twice higher resolution than that of existing products.
- It performs high-precision engraving and marking.
- The finer detail and higher engraving/marketing quality are achieved.

Multifunction: Flat and rotary clamps / engraving, cutting and marking

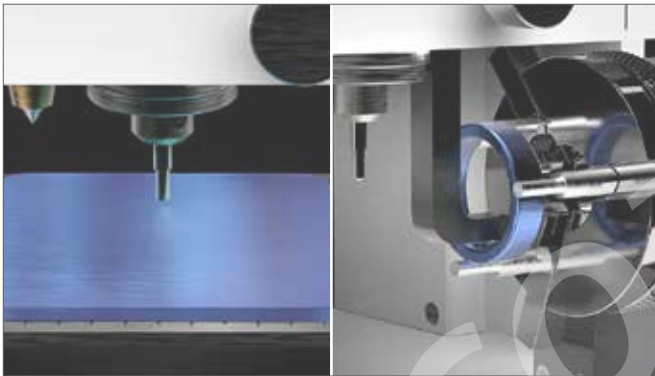

For both flat and rotary all-in-one engraver

- This single engraving machine can do both flat engraving and rotary marking.
- The machine has a flat clamp to engrave, cut, and mark such a pendent and plate.
- A rotary clamp is also embedded by default, which engraves a ring, bangle, pen, etc.

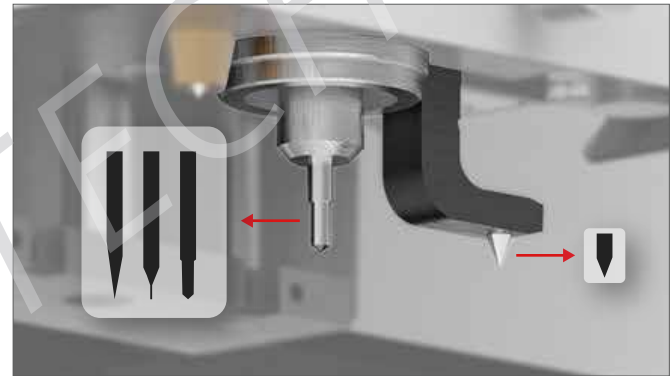

Various tools support

- A variety of tools are available to support all of engraving, cutting, and marking.
- The machine supports the spindle rotation graving and cutting that rotates a tool to process materials; and scribing marking that presses down materials to mark.
- An internal diameter-engraving tool and L-tool are embedded to engrave the inner diameters of rings/bangles.

Features for easy and convenient use

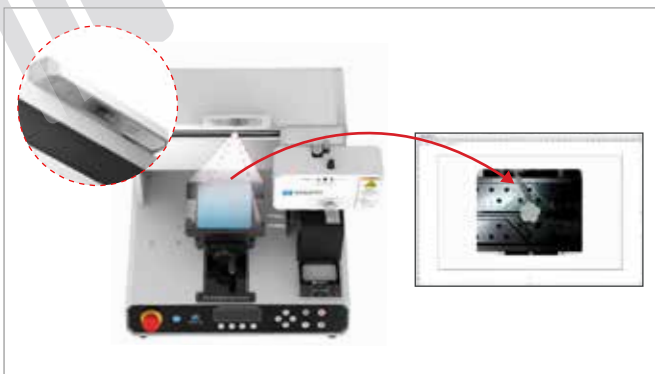

Simple engraving position control

- Simple engraving position control for anyone to easily use the machine.
- Intuitive way of machine operation with an embedded camera directly showing a material to design and engrave instantly.
- A laser pointer is built in for users to easily find and adjust engraving positions.



Simple functional expansion

- Various device options are provided for simple functional expansion.
- Users can easily replace clamps thanks to the removable structure of the machine.
- Users can establish the optimal environment for their purpose of engraving machine use based on different device options.

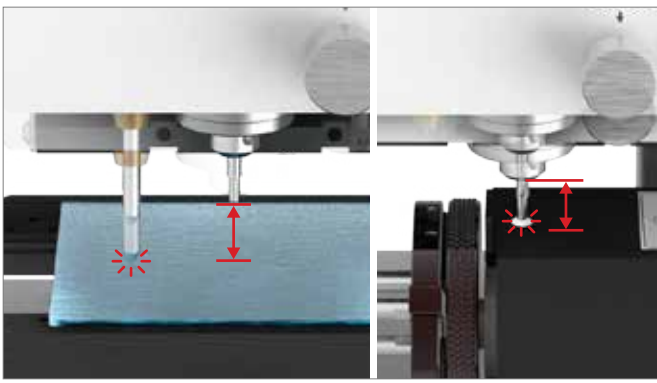

Auto measurement

- Auto measurement supports very simple machine use.
- A material measuring sensor detects the height of a material and adjusts the origin point automatically.
- A tool measuring sensor measures the length of a tool and adjusts the origin point automatically.



Bluetooth wireless connection

- Bluetooth wireless communication is supported.
- Users can operation the machine using not only USBs but also wireless manner.
- They can control the machine wirelessly in own tablets through the Bluetooth wireless communication. Android tablet, iPad, Window tablet, and most of the tablets are available.

Design and software for all users



Compact and modern design

- Compact and modern design installable in any places such as shops, workrooms, and plants.

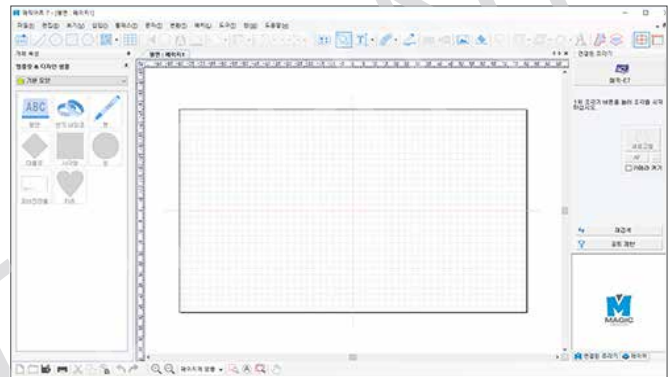

Dedicated software easy to use

- MagicArt7 is provided, which is convenient and easy for anyone to perform engraving, cutting, and marking for various purposes.

Sample

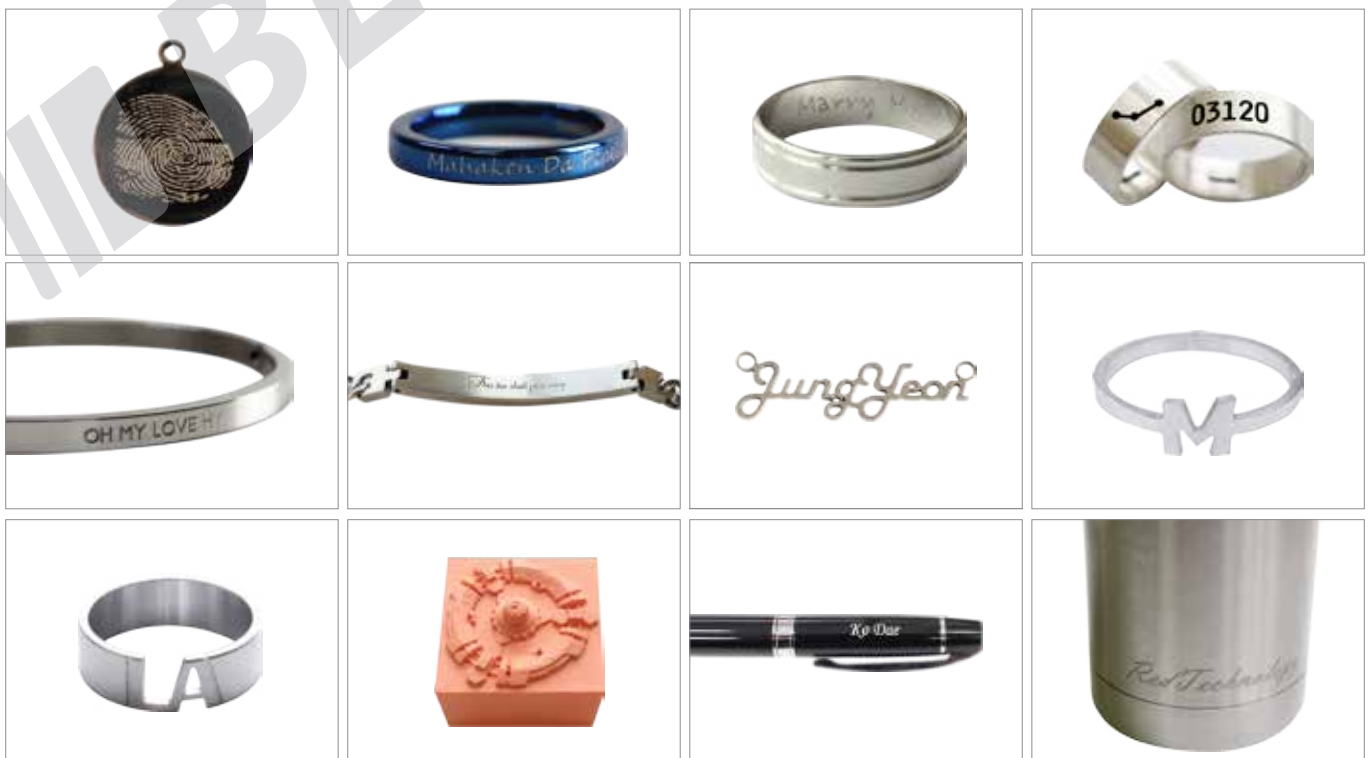

Functions and applications

Engraving Precise engraving in a set size and depth.



- Engrave letters, logo, patterns, etc. on diverse materials such as wood, acryl, modeling board, aluminum, and brass with different tools.
- Engrave name tags, all sorts of labels, door signs, etc., 2.5-dimensional engraving.

Cutting Cut varied materials in desired forms.

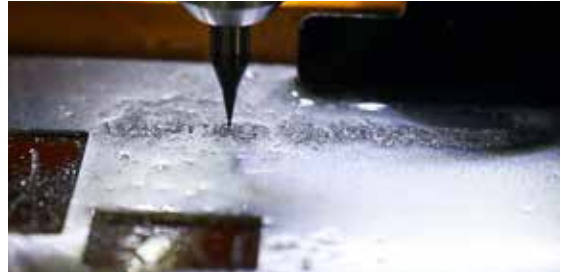

- Cut to manufacture initial necklaces, jewelry, etc.
- Cut flat plate-type wax for engraving and cast immediately.

Pendant engraving

Engrave letters, patterns, etc. on various materials.



- Engrave on jewelry products such as necklace, bangle, earrings, dog ID tags, army name tags and other pendants.
- Engrave using a diamond tool to make inerasably deep carving in excellent quality while minimizing material damage and loss.

Ring engraving

Engrave letters, patterns, etc. on the outer/inner ring diameters.



- Tools embedded for outer/inner diameters each to auto engraving when switched to a desired mode.
- Engrave with a diamond tool to minimize material damage and loss.
- Inerasably deep marking in excellent quality.

Pendant engraving

Engrave letters, patterns, etc. on various materials.



- A dual-mode tool embedded to engrave on the inner diameter side, which auto carves when switched to a desired mode.

Photo engraving

Mark images using various techniques.



- Engrave or mark photographic images on various materials using 4 different engraving methods.
- Express images on materials in techniques such as dot marking, dot halftone engraving, line halftone engraving, and lithophane engraving.

Engraving on outer cylinder diameter

Engrave on cylindrical materials.



- Engrave on cylindrical materials such as mugs, wine glasses, and drinking glasses.
- Fix easily various cylinder-formed materials using a tailstock and tailstock cone.

Pen engraving

Engrave on diverse forms of pens.

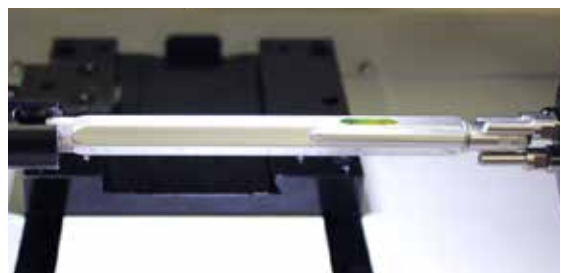

- Engrave on various-formed pens.
- Fix easily pens in various forms using a tailstock and pen clamp.

Product specifications

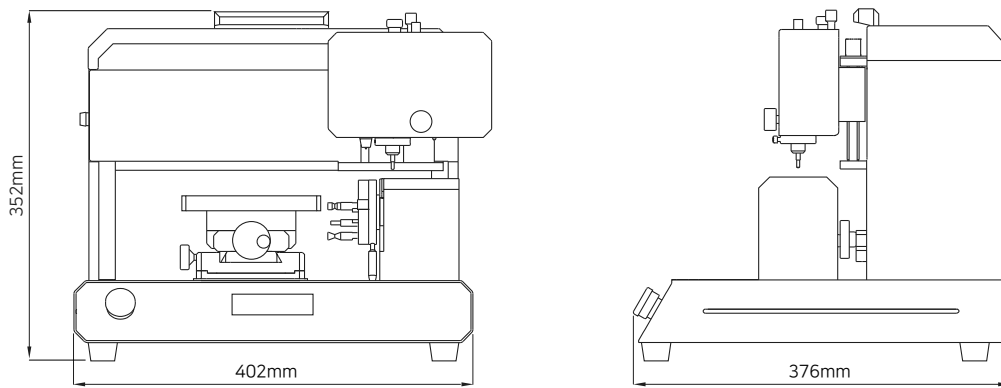

Model	MAGIC™-E7	Spindle RPM	MAX 15,000RPM
Size	402mm(W) x 376mm(D) x 352mm(H)	DC motor output	38W
XYZ axis stroke	236.5mm(X) x 179mm(Y) x 40mm(Z)	Weight	57lbs
Resolution	0.0025mm(XY) / 0.000625mm(Z) / 0.028125°(A)	Voltage	AC 100V ~ 240V, 50Hz/60Hz
Max material height	60mm	Power consumption	47W
Rotary outer diameter	17.5 ~ 80mm	Flat engraving area	112mm x 100mm
Rotary inner diameter	14 ~ 78mm	Temperature/Humidity	32°F ~ 104°F/10% - 85%
Bluetooth SPEC	Bluetooth BLE(Bluetooth 5.0) / Communication Range : Class 2(32.8ft) / Tx Output : MAX +4dBm / Frequency Band : 2.4 GHz		

Options

Dust collector (dry type)

Collects dust and chips generated while engraving.



Dust collector (wet type)

Discharges cutting oil and absorbs in together with chips at the same time to filter and circulate.



Tailstock

A clamp that firmly fixes a long cylindrical material in order not to let it tilt to one side.



Cutting clamp

Cuts a board while it is being pressed down, fixed, and sunk into cutting oil.



Curved tag adapter

Fixes firmly materials with curved surface.



Ring adapter

A part to more firmly fix a ring using a tailstock when engraving on the outer ring diameter.

